

ICARUS _MULTISTAND

Giulia Archimede, 2019

Dimensions:
133h x 30Ø cm
(52.36h x 11.81Ø inches)

Weight:
10kg
(22 pounds)

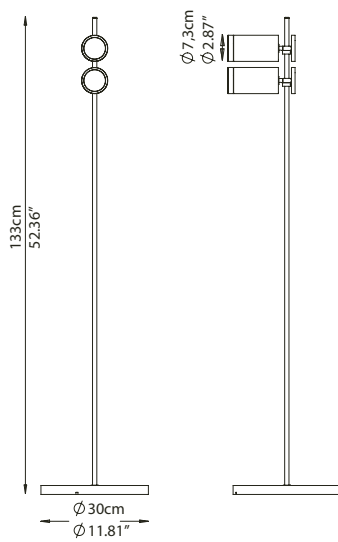

ICARUS _MULTIGROUND

Giulia Archimede, 2019

Dimensions:
90h x 15Ø cm
(34.43h x 5.90Ø inches)

Weight:
9kg
(19,8 pounds)

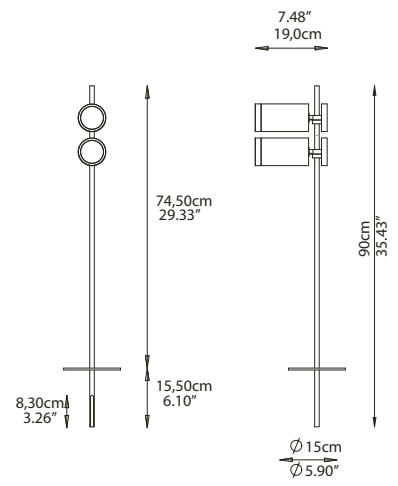

Version	Passive without crossover	Passive without crossover
Speaker Type:	2 x 2" Wide Band	2 x 2" Wide Band
Nominal Impedence:	4Ω	4Ω
Crossover:	recomended DSP settings: HP=200 Hz; 12 dB/oct	recomended DSP settings: HP=200 Hz; 12 dB/oct
Frequency Range:	220-20.000Hz (-6dB) (recommended DSP setting)	220-20.000Hz (-6dB) (recommended DSP setting)
Sensitivity (1W - 1m)	83 dB	83 dB
Speaker Peak Power	60W	60W
Speaker RMS Power	50W	50W
Lighting Mood	N/A	N/A
High-z on Board	Optional (Voltage 70-100 V Power 10 W)	Optional (Voltage 70-100 V Power 10 W)
Body Materials	Concrete (gray, black, white, red) Marble, travertine and alterntive stones	Concrete (gray, black, white, red) Marble, travertine and alterntive stones
Metal Components Materials	Stainless steel 304 (polished, satin, painted matt black) Stainless steel 316L, Oxidized Brass	Stainless steel 304 (polished, satin, painted matt black) Stainless steel 316L, Oxidized Brass

TECHNICAL INFO